

## Specification of BL-GU10-3XPC/ XPE

### Product Image



dimension  $\Phi 50 \times 60 \text{mm}$

### Product Highlights

- \* Dimmability

Applicable for TRIAC dimmer, working with 95% of dimmers being sold in market, plug-in replacement of current traditional lamps, no change required for dimmers and (or) circuits, dimming range is from 10%~100%, no flickering.

- \* Outstanding Performance

Efficient > 80% , PF > 0.9, life span > 50,000 hours.

### Application

Desktop, Aisle, showcase, residential lighting for bedroom, studyroom, living room etc. commercial lighting for office, hotel lobby, shop, exhibition room etc.

### Features

- \* ITEM NUMBER: BL-GU10-3XPC/ XPE
- \* LED CHIP Q'TY: 3PCS LED
- \* LED TYPE: CREE XPC/ CREE XPE
- \* AVAILABLE INPUT VOLTAGE: 85~145V AC and 190~265V AC
- \* APPLICABLE DIMMERS: TRIAC DIMMER FOR LUTRON, TEVITON, LEGRAND, CE, ORSAM etc.
- \* INPUT POWER: 5.4W
- \* OUTPUT POWER: 4.4W
- \* TOTAL LENGTH:  $\Phi 50 \times 60 \text{mm}$
- \* OUTPUT CURRENT: 400mA

## Specification of BL-GU10-3XPC/ XPE

- \* LUMEN OUTPUT: CREE XPC : WW:250lm, CW:350lm  
CREE XPE : WW:310lm, CW:380lm
- \* COLOR RANGE: 2,700~6,500K
- \* BEAM ANGLE: 15/25/45degrees
- \* REFLECTOR EFFICIENCY: 90%
- \* LIFE SPAN: >50,000 HOURS
- \* BODY TEMPERATURE: <65°C
- \* LED WORKING TEMPERATURE: <72°C
- \* CRI: Ra> 80
- \* NET WEIGHT: 80g
- \* HOUSING MATERIAL: ALUMINIUM EXTRUSTION
- \* NO UV OR IR RADIATION
- \* CERTIFICATION: CE , ROHS.

### Packing Specification

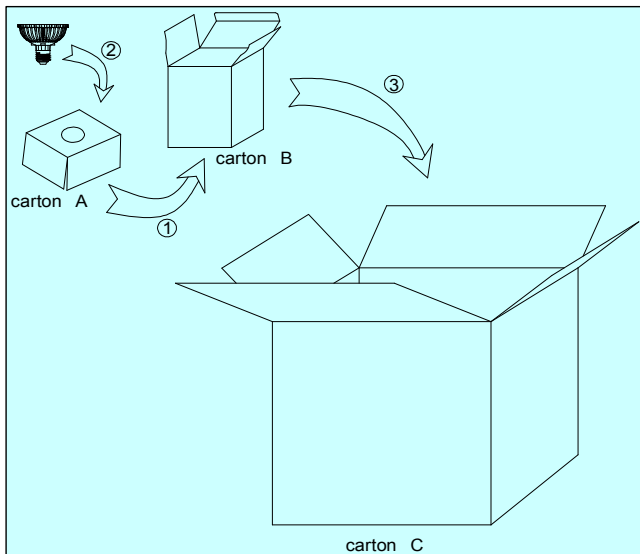

Carton dimension 55x55x80cm, PACK size:100 pcs

Address: TongSheng Buidling, Shanghenlang Industrial Park, Dalang, Long Hua, Baoan, Shenzhen, Guangdong, China 518001

[www.bravoled.com](http://www.bravoled.com)