



Bravoled Lighting Manufacturing Co. Ltd.

Specification of BL-QP60-A1-SemiLED/ CREE XRC/ XRE

Product Images



Product Highlights

- * Dimmer Application

Applicable for TRIAC dimmer, working with 90% of dimmers being sold in market. Plug-in replacement of current traditional lamps, no change required for dimmers and (or) circuits.

- * Outstanding Performance

Efficient > 80% , PF > 0.9, Life Span > 50,000 hours.

Application

Desktop, Aisle, showcase, residential lighting for bedroom, studyroom, living room etc. commercial lighting for office, hotel lobby, shop, exhibition room etc.

Features

- * BULB TYPE: BL-QP60-A1
- * LED CHIP Q'TY: 5x1W
- * BASE TYPE: E27/E26
- * LED TYPE: SemiLED & CREE-XRC/XRE
- * INPUT VOLTAGE: 85-145V AC or 90-265V AC with reversed polarity protect
- * TOTAL LENGTH: 124mm
- * INPUT POWER: 6W
- * OUTPUT POWER: 4.8W
- * LUMEN OUTPUT: Semi/ CREE XRC: WW:335lm, CW:430lm;
CREE XRE: WW:350lm, CW:450lm
- * OUTPUT CURRENT: 320mA



Specification of BL-QP60-A1-SemiLED/ CREE XRC/ XRE

- * BEAM ANGLE: 120 degree
- * REFLECTOR EFFICIENCY: 90%
- * BODY TEMPERATURE: <65°C
- * LED WORKING TEMPERATURE: <72°C
- * COLOR TEMPERATURE: Warm White:2700-3500K;Cool White:5000-6500K
- * DIMMABILITY: Compatible with Triac dimmers on market such as Lutron, Leviton, legrand, Osram,and GE etc. dimming range is from 5~100% and v
- * CRI: Ra> 80
- * GROSS WEIGHT: 120g
- * HOUSING MATERIAL: ALUMINIUM BASE AND GLASS LENSE
- * NO UV OR IR RADIATION
- * LIFE SPAN: >50,000 HOURS
- * WARRANTY: 2 Years.
- * CERTIFICATION: CE, ROHS, UL pending.

Packing Specification

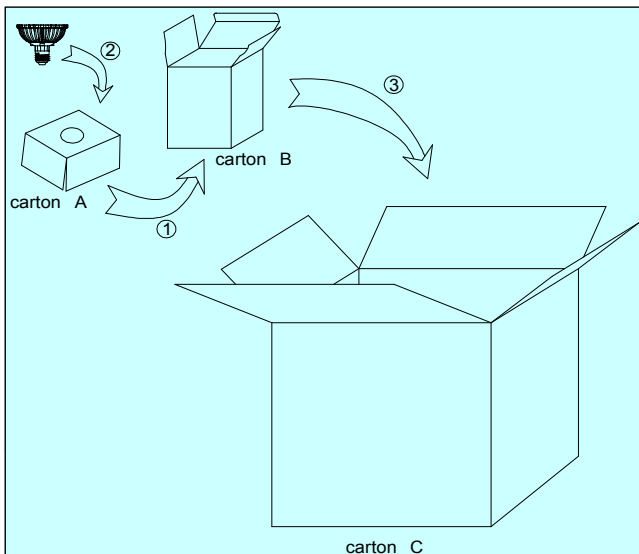

Carton Dimension 73x73x122mm, Pack Size: 48pcs.

Address: TongSheng Buidling, Shanghenlang Industrial Park, Dalang, Long Hua, Baoan, Shenzhen, Guangdong, China 518001